



An IC Design Company

5F-14, No.12, Lane 609, Chung Hsin Rd., Sec.5, San Chung City,  
Taipei Hsien, Taiwan

Tel. +886 2 2278 2001 +886 2 2278 4815

Fax +886 2 2999 5349

E-MAIL: service@songrock.com.tw

**SongRock**  
TechnologyCorp.

## FINGERPRINT IDENTIFICATION IC

S8112

Bio-Crypto Controller

QFN-72

Information provided here is subject to change without notice. All rights reserved

### OVERVIEW

The S8112, a Single chip Bio-Crypto device which offers highly secure access control system. It integrates a 32-bit microprocessor with two 8k byte cache, one 512k byte flash memory, large system SRAM and powerful I/O to provide a high performance biometric security system which built in proven fingerprint extraction algorithm (winner of International Fingerprint Verification Competition 2000) and Public Key Infrastructure (PKI) function.

### TYPICAL APPLICATION

- General locking device
- Private/secret key deployment
- Desktop computer access
- Access control and monitoring
- Phone, keyboard, door, safe access
- Toy, Personalized electronic pets
- Replace keypad for entering the password

### TECHNICAL FEATURES

- Powerful I/O interface : UART, I2C (Master/Slave), Wireless Interface and 26 General Purpose I/O control.
- Enrolment/De-enrolment and Authentication can be performed through UART or wireless interface.
- Once owner is enrolled, other users of the same device can only be enrolled with owner's approval.
- Ownership is transferable if granted by current owner.
- Provide more than 512k byte of flash memory for external MCU.
- No reading of the confidential area in flash memory is allowed.

- RSA key pair are generated internally, only public key is allowed to be read externally, private key is always resided in the silicon.
- Build-in AES algorithm for data encryption.
- Provide maximum security as the biometric matching is performed in the silicon
- Provide a set of protocol through UART for external MCU to control the crypto function, biometric verification and I/O logic function
- With different type of line drivers, UARTs can function as RS232, RS422 or RS485 transmission
- Support most of the fingerprint sensor in the market, like STmicro, Fujitsu touch/sweep sensor etc. Allow plug-in for new sensor type.
- Power management for maximizing battery life of mobile devices

### FUNCTIONS

The three basic functions:

- **Basic Stand Alone:** Capable to enroll (Read an finger print image from sensor), De-Enroll (Search and remove the related finger print data) and authenticate (Read the finger print image and match with the stored template)
- **Internal MCU Emulation:** Allow to utilize the internal MCU emulation to interface with the external devices.
- **External MCU:** capable to interface with external MCU to communicate the finger print authentication result.



An IC Design Company

5F-14, No.12, Lane 609, Chung Hsin Rd., Sec.5, San Chung City,  
Taipei Hsien, Taiwan

Tel. +886 2 2278 2001 +886 2 2278 4815

Fax +886 2 2999 5349

E-MAIL: service@songrock.com.tw

**SongRock**  
Technology Corp.

**FINGERPRINT IDENTIFICATION IC**

**S8112**

Bio-Crypto Controller

QFN-72

Information provided here is subject to change without notice. All rights reserved

**BLOCK DIAGRAM**

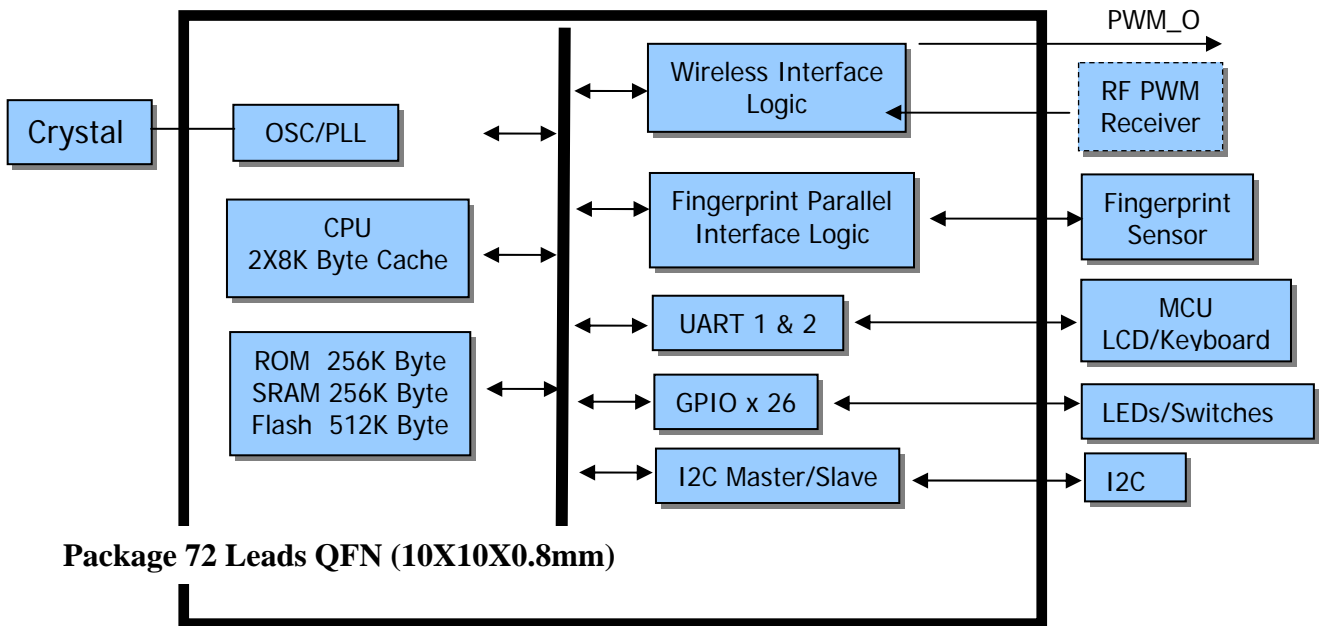

Package 72 Leads QFN (10X10X0.8mm)

**FINGER PRINT VERIFICATION SPECIFICATION**

Fingerprint template size	360 byte / fingerprint template
Max fingerprint templates	250
False Acceptance rate (FAR)	< 1 in 10000
False Rejection rate (FRR)	< 1 in 1000
Verification time (100 templates)	< 1 sec

**DC PARAMETERS**

Parameter	Ratings	Unit
Operating Temperature Range (T <sub>opr</sub> )	0 to +70	°C
Storage Temperature Range	-40 to +125	°C
Lead Temperature Range (soldering, 10 seconds)	+260	°C
Maximum IO Supply Voltage, V <sub>IO</sub>	+3.63	V
Maximum Core Supply Voltage, V <sub>dd</sub>	+2.75	V
Maximum Input Voltage	+5.00	V

*Note: The absolute maximum ratings are rated values, which must not be exceeded during operations, even for an instant. Any one of the ratings must not be exceeded. If any absolute maximum rating is exceeded, a device may break down or its performance may be degraded, causing it to catch fire or explode resulting in injury to the user. Thus when designing products which include this device, ensure that no absolute maximum rating value will ever be exceeded.*